

72-8355-250

7/11

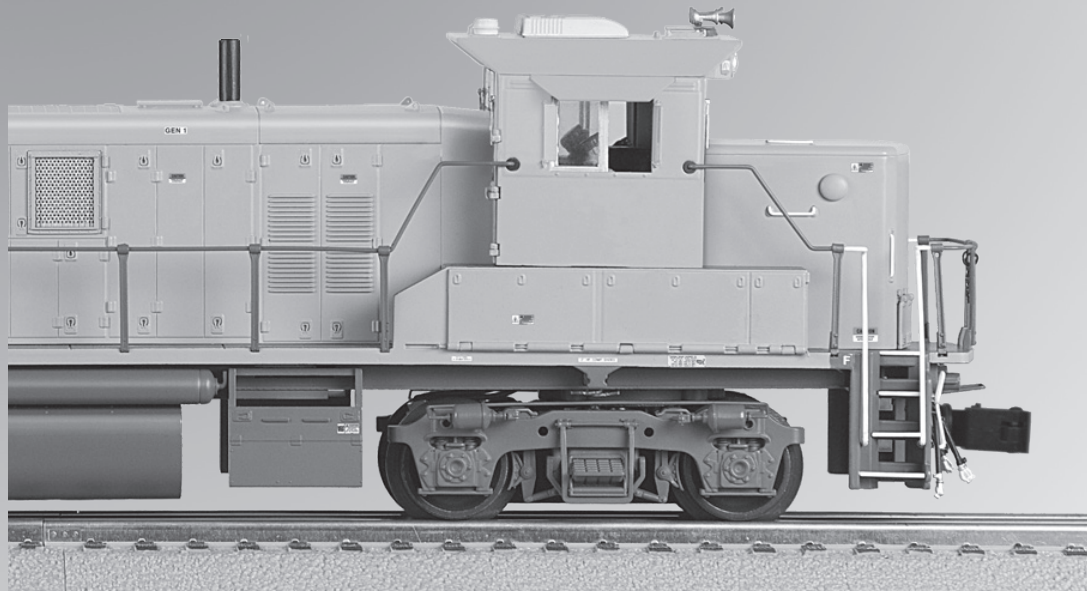

Lionel Genset Diesel Locomotive Owner's Manual

Featuring



Congratulations!

Congratulations on your purchase of this Lionel LEGACY diesel locomotive! On the outside, this locomotive features numerous details and expert decoration in your favorite livery. Inside the body, this locomotive is equipped with some of the most advanced sounds and controls in model railroading. This powerful locomotive is ready for duty on your layout.

Prototypical Genset locomotives have three diesel engines that cycle on and off to provide variable pulling power. To simplify maintenance, the engines are rotated in use so that the total hours on each is kept relatively equal.

When idling at RPM level 1 for an extended period, the Genset will enter standby mode. The diesel engine will automatically turn off and a repeating electronic alert beep will sound to warn the crew that the locomotive is in standby. To maintain fluid and temperature levels, the locomotive will automatically sound a long beep and then restart one of its engines when necessary.

Contents of your locomotive box

1 Powered locomotive

2 Replacement traction tires

1 Owner's manual

1 Engine memory module

The following Lionel marks are used throughout this catalog and are protected under law. All rights reserved.

Lionel®, *LEGACY™*, *FasTrack™*, *TrainMaster®*, *Odyssey®*, *RailSounds®*, *CrewTalk™*, *TowerCom™*, *DynaChuff™*, *StationSounds™*, *Pullmor®*, *ElectroCoupler™*, *Magne-Traction®*, *CAB-1® Remote Controller*, *American Flyer®*, *Lionel ZW®*, *ZW®*, *MagniVision®*, *TMCC®*, *Lionelville®*, *Wireless Tether™*, *Powerhouse™*, *LionMaster®*, *Conventional Classics™*, *Postwar Celebration Series™*, *TruRail™*, *PH-1 Powerhouse®*, *Powermaster®*, *Powerstation-Powerhouse®*, *Accessory Motor Controller™*, *AMC™*, *Accessory Switch Controller™*, *ASC™*, *Action Recorder Controller™*, *ARC™*, *Track Power Controller 300™*, *TPC 300™*, *Track Power Controller 400™*, *TPC 400™*, *Block Power Controller™*, *BPC™*, *Operating Track Controller™*, *OTC™*, *FatBoy™*, *Lionel Lines®*, *Joshua Lionel Cowen Series™*, *Lockon®*, *TrainSounds™*, *MultiHorn™*, *MultiHorn™*, *Cboo-Cboo™*

Table of contents

Running your locomotive

LEGACY Control operations	4
TrainMaster Command Control (TMCC/Command) operations	5
Conventional transformer operations	6

Locomotive basics

Adding smoke fluid to your locomotive's smoke generator	7
Locomotive switch locations	8
Installing the battery	9
Assigning your locomotive a new ID# (LEGACY and TMCC)	10
Lash-ups (for LEGACY operations only)	11

LEGACY Control System operations

The LEGACY CAB-2 Remote Controller	12
The Velocity Throttle	13
The Multi-Controller	13
The Train Brake Slider	13
The Warning Sound Controller	14
The Speed Bar	14
EFX Trim and EFX Bar Graph	15
Leaving the Preset Speed Screen	15

LEGACY RailSounds Sound System operations

LEGACY RailSounds sound system	16
LEGACY RailSounds Sequence Control	17
CrewTalk dialog and TowerCom announcements in the LEGACY environment	18
LEGACY RailSounds sound system dialog on a round trip	19

TrainMaster Command Control operations

CAB-1 Remote Controller commands	20
CAB-1 Remote Controller numeric keypad commands	21-22
Setting the smoke level	22

Conventional transformer operations

Using the LEGACY RailSounds sound system in the conventional environment	23
Activating CrewTalk dialog and TowerCom announcements	24
Locking your locomotive into a single direction	25

Odyssey II Speed Control system operations

Odyssey II Speed Control operations	26
Odyssey II Speed Control LEGACY Control operation	26
Odyssey II Speed Control TrainMaster Command Control operation	26
Odyssey II Speed Control conventional transformer operation	26

Maintaining and servicing your locomotive

Reprogramming your locomotive to restore features	27
Lubricating your locomotive	28
Servicing your locomotive's lamps	29
Replacing the traction tires	29
Locomotive diagnostics	30
Notes	31
Lionel Warranty	32

Running your locomotive

Note! Power your locomotive with an alternating-current (50-60Hz AC) transformer only. Powering your locomotive with a direct-current (DC) transformer, or in excess of 19 volts AC, may result in damage to sensitive electronic components.

Note! Your locomotive requires Lionel or Lionel-compatible 0-42 (0-54 recommended) or larger track curves.

LEGACY Control operations

For the finest operating experience, your locomotive is fully compatible with the LEGACY Control System. To operate in LEGACY mode, you need a LEGACY Command Base and LEGACY CAB-2 Remote Controller (6-14295).

Your commands are sent by the CAB-2 Remote Controller to the Command Base, which sends a digital code through the rails to your locomotive. Your locomotive will not respond until it recognizes its unique ID#, so you can operate multiple Command-equipped locomotives on the same track at the same time.

1. Turn off track power, and then plug in the LEGACY Base and connect it to the track.
2. Place your locomotive on the track.
3. Increase track power voltage to full power (no more than 19 volts AC). If a circuit breaker trips when you turn on the Lionel power supply, check the wheels of your locomotive to make sure they are all securely on the track. Check to make sure the track is free of all metals that may cause a short circuit.
4. As illustrated in Figure 1, press ENG and 1 (or your selected ENG ID#) to address the locomotive with your LEGACY CAB-2 Remote Controller.
5. Press the Start Up button on your LEGACY CAB-2 Remote, shown in Figure 2. Then, throttle up and move 'em out! Your engine sound will start up, and the locomotive-specific touch screen buttons will populate the remote. For more information on operating your locomotive with the LEGACY system, please refer to the LEGACY section of this manual. Additional information is also found in the LEGACY System Manual, available online at www.lionel.com.

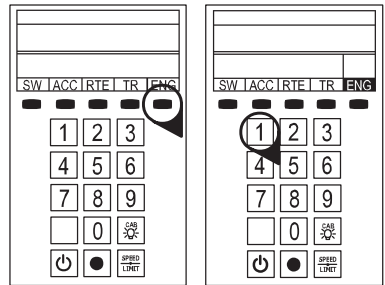

Figure 1. LEGACY engine selection

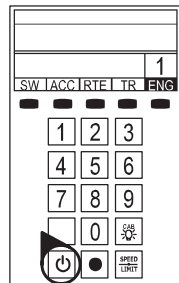

Figure 2. LEGACY start-up

Running your locomotive

Note! Power your locomotive with an alternating-current (50-60Hz AC) transformer only. Powering your locomotive with a direct-current (DC) transformer, or in excess of 19 volts AC, may result in damage to sensitive electronic components.

Note! Your locomotive requires Lionel or Lionel-compatible 0-42 (0-54 recommended) or larger track curves.

TrainMaster Command Control (TMCC) operations

For operation in the TrainMaster Command Control environment, you need a TrainMaster Command Base (6-12911) and a CAB-1 Remote Controller (6-12868). Refer to your TMCC System Manual for complete information. **To access all the locomotive's features, you must operate in the LEGACY environment, as discussed on the previous page.**

Your commands are sent by the CAB-1 Remote Controller to the Command Base, which translates the command into digital code. That code is sent through the outside rails to your locomotive, which will not respond until it recognizes its unique ID#. TrainMaster Command Control gives you the power to operate multiple Command-equipped locomotives on the same track at the same time.

- 1. Turn off track power, and then plug in the Command Base and connect it to the track.**
- 2. Place your locomotive on the track.**
- 3. Increase track voltage to full power (no more than 19 volts AC).** If a circuit breaker trips when you turn on the Lionel power supply, check the wheels of your locomotive to make sure they are all securely on the track. Check to make sure the track is free of all metals that may cause a short circuit.
- 4. Press ENG and 1 (or the ENG ID# you set) to address your locomotive with your CAB-1 Remote Controller.**
- 5. Throttle up and move 'em out.**

For more information, please refer to the TrainMaster Command Control operations section of this manual or the TMCC System Manual, available online at www.lionel.com.

Running your locomotive

Conventional transformer operations

Note! For Conventional operation, a Command Base must not be powered up anywhere in the area, even if it is not connected to the track. If a base is detected, your locomotive will default to Command mode.

Note! Power your locomotive with an alternating-current (50-60Hz AC) transformer only. Powering your locomotive with a direct-current (DC) transformer, or in excess of 19 volts AC, may result in damage to sensitive electronic components.

Note! Your locomotive requires Lionel or Lionel-compatible O-42 (O-54 recommended) or larger track curves.

- 1. With track power off, place your locomotive on the track.**
- 2. Power up the track.** If a circuit breaker trips when you turn on the Lionel power supply, check the wheels of your locomotive to make sure they are all securely on the track. Check to make sure the track is free of all metals that may cause a short circuit.
- 3. Move 'em out!** When the locomotive's headlight illuminates and the LEGACY RailSounds sound system starts, press the DIRECTION button on your transformer to sequence your locomotive through the repeating pattern of operations: neutral, forward, neutral, reverse, neutral, and so on. You may also briefly turn off track power to advance the locomotive to the next operating state. Adjust the throttle until your locomotive moves at your desired speed.

Note! When placing your locomotive on your layout for the first time and after power interruptions lasting longer than five seconds, it will start out in neutral.

We recommend that you operate your LEGACY locomotive with Odyssey II Speed Control turned on. You may choose to operate your locomotive without speed control by placing the Odyssey II Speed Control System switch to the NO ODY position. See Figure 4 on page 8 for the location of the switch.

Use the **HORN** and **BELL** buttons on your transformer to activate those features. Adjust the volume using the volume control knob. Refer to Figure 4 on page 8 for the location of this control. For more information, please refer to the Conventional transformer operations section of this manual.

Locomotive basics

Adding smoke fluid to your locomotive's smoke generator

Your locomotive is equipped with a smoke generator that produces safe, clean, white smoke during operation. Grasp the **center stack** by the sides and pull it straight up to remove it, then add 10-20 drops to the hole (shown in Figure 3) to prime the unit the first time you run the locomotive or after being stored for an extended period of time, and then add 10 to 20 drops to refill when smoke production decreases. When refilling, **DO NOT EXCEED 20 DROPS** as this can cause your smoke units to become oversaturated allowing leakage onto the electronics. Note that operating your locomotive's smoke unit without smoke fluid will cause damage to the heating element.

If you prefer to operate your locomotive without smoke, locate the smoke unit switch and slide it to the NO SMK position. Refer to Figure 4 on page 8 for the location of the switch.

Note! For best performance, we recommend using Lionel smoke fluid only. Do NOT use smoke fluid from ready-to-run train sets.

Note! Add smoke fluid to the hole under the **center stack** only. Grasp the stack by the sides and pull it straight up to remove it.

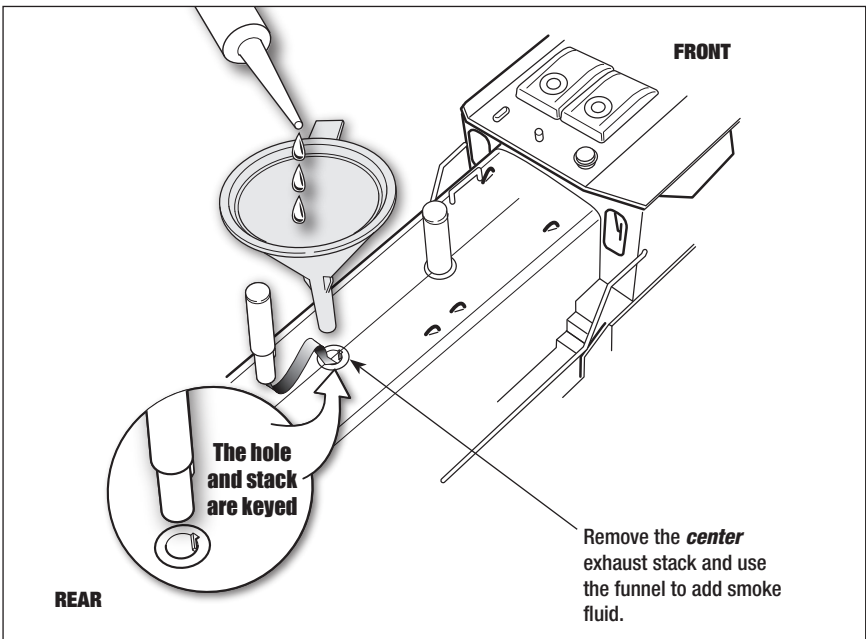

Figure 3. Smoke fluid location

Locomotive basics

Locomotive switch locations

The functions of your locomotive's switches are outlined below. Refer to Figure 4 for the location of the switches. *The instructions below are specific to this particular locomotive; note that available features (and switches) may differ from other locomotives and locomotive sets.*

Smoke Unit Switch (SMK/NO SMK)

Used to turn the smoke unit function on and off.

Program-Run Switch (RUN/PGM)

Used to assign an ID# and to reprogram the locomotive for LEGACY and Command operation when the switch is in the PGM position. Also used to “lock” your powered locomotive in a single direction, or neutral, in conventional operation when the switch is placed in the PGM position.

Odyssey II Speed Control System Switch (ODY)

Used to turn the Odyssey II Speed Control System on and off.

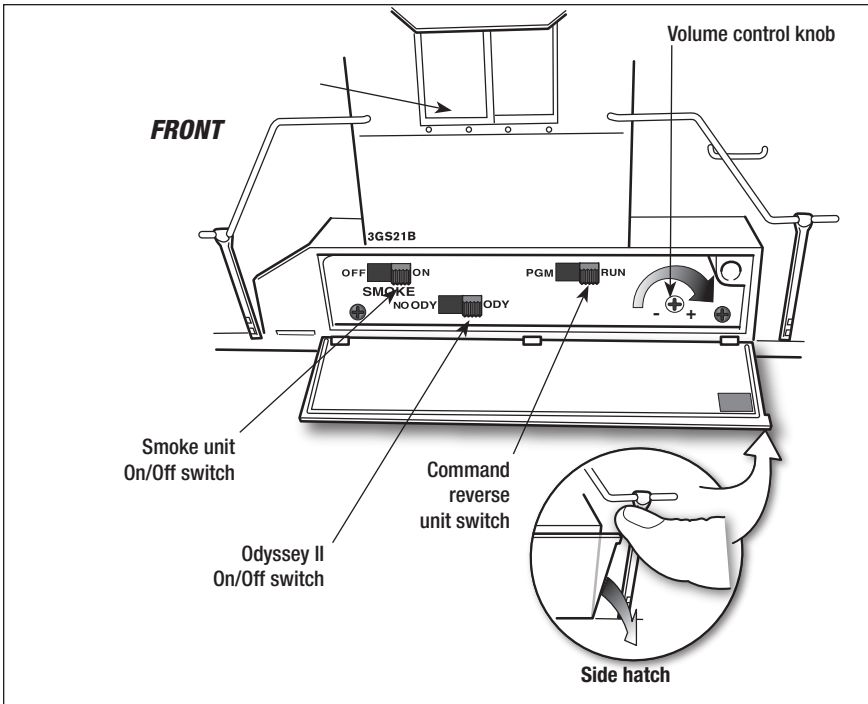

Figure 4. Locomotive switch locations

Locomotive basics

Installing the battery

Although the LEGACY RailSounds sound system is powered through the track, you may choose to install a nine-volt alkaline battery if you find that the sound system shuts down during track power interruptions (for example, at a switch or over a dirty section of track). Follow these steps to install the battery.

Note! If the RailSounds sound system turns off during interruptions in track power, you may need to replace the battery. Use only alkaline batteries.

1. Lift up and remove the hatch from the front nose of the locomotive.
2. Remove the protective cover from the battery harness.
3. Snap the battery harness onto the nine-volt alkaline battery's terminals.
4. Slide the battery into the battery well in the nose of the locomotive.
5. Replace the hatch on the locomotive's nose.

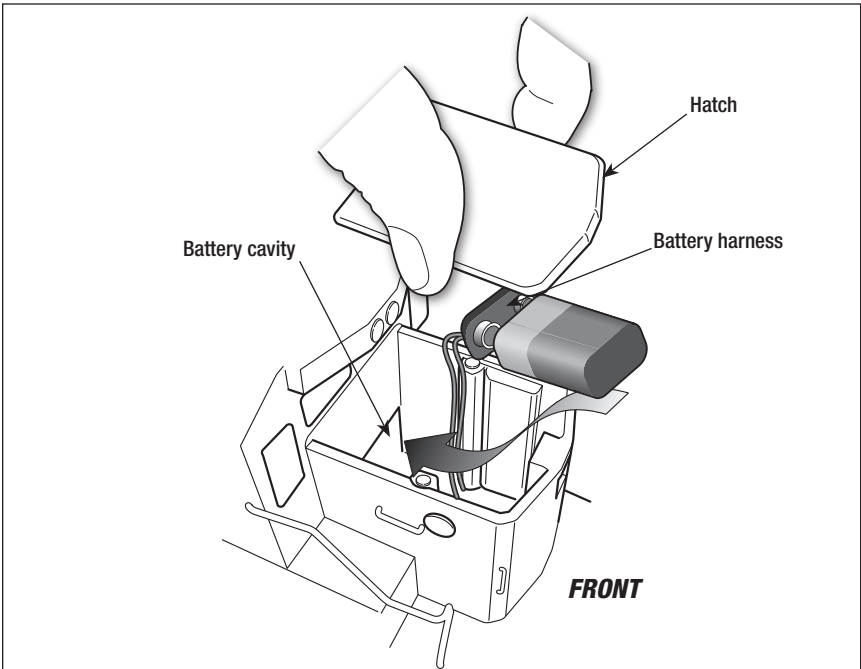

Figure 5. Battery installation

Locomotive basics

Assigning your locomotive a new ID#

For operation in the LEGACY or TMCC environment, you will want to give each unit a unique ID#. The locomotive will respond to commands associated with its ID# while all other units will disregard these commands. ***This procedure is not necessary for conventional (non-Command) operation.***

- 1. Slide the Command reverse unit switch on your locomotive to the PGM position. See Figure 4 on page 8.**
- 2. Place the locomotive on the track.**
- 3. Connect the Command Base and plug it in.**
- 4. Power up the track.**
- 5. Press ENG on the CAB-1 or CAB-2 remote.**
- 6. Enter the unique ID#. Choose any number from 1 to 98 that has not been assigned to another locomotive (ENG). We recommend using a part of your locomotive's road number.**

Note! All LEGACY locomotives respond to ENG 99. We recommend that you reserve ID# 99 as a "universal" ID#.

- 7. Press SET. The locomotive's horn will sound, or the headlights will flash if the RailSounds sound system is off.**
- 8. Slide the Command reverse unit switch back to the RUN position.**
The locomotive's ID# has been set. Be sure to record the new ID# for your reference.

Locomotive basics

Lash-ups (for LEGACY operations only)

In the Command environment, building a lash-up allows you to control your locomotive as one in a prototypical manner. It is still possible to control any of the engines in the lash-up individually. When you issue a train command, the individual engine you were controlling will return to the group. If there is a difference in speed, the individual Engine will return to the speed of the lash-up at the rate set in the train momentum.

To build a lash-up, assign a unique engine (ENG) ID# to each unit. See page 10 for details.

1. Address the train ID# you wish to create or edit, 1 to 99.
2. Press INFO.
3. Press BUILD softkey (button directly under BUILD).
4. Enter the front engine number. It is not necessary to enter ENG, just enter the #. It will appear in the blinking box.
5. Press ADD to add the front engine. The engine will move to the right and the blinking box will be ready for your next engine to be added.
6. Enter the second engine ID# in the blinking box.
7. Press ADD to add the second engine. The engine will move to the right and the blinking box will be ready for your next engine to be added.
8. Add all the engines you want in your lash-up in this manner.
9. To change the direction of an engine in your lash-up, turn the Velocity Throttle to move the engine you want into the blinking box. Then press DIR to change the direction of the engine.
10. To delete an engine in your lash-up, turn the red Velocity Throttle knob to move the engine you want to delete into the blinking box. Then press DEL.
11. To save your lash-up, press SET. Watch the onscreen prompts and wait until you see the message TRAIN CREATED.
12. Press CTC to exit to the operating screen.

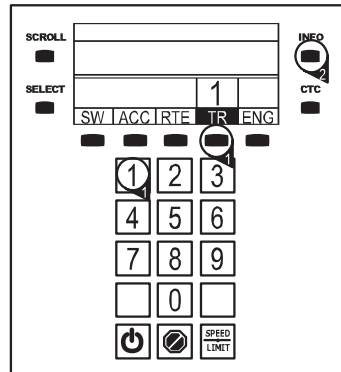

See reference numbers 1 and 2

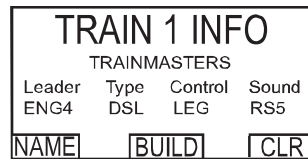

See reference number 3



See reference number 4

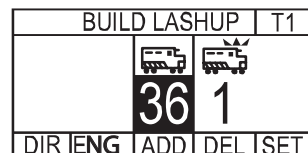

See reference numbers 6 and 7

LEGACY Control System operations

The LEGACY CAB-2 Remote Controller

Main Display

Displays real-time information about your railroad system. Displays real-time feedback of operation.

Scroll Button

Navigates through the entire list of Engines, Trains, Switches, etc

Select Button

Performs addressing by 3-4 digit road number.

Touch Screen Key Pad

A group of touch sensitive keys with icons for each function. These keys serve many purposes and their icons change accordingly.

Train Brake Slider

This slider is used to increase or decrease the amount of Train Brake affecting the engine or train.

Train Link Button

Quick select of Train-Link devices (LEGACY Control System Version 1.3)

AUX-1/Thru Button

Press to view the Control Panel while operating. Controls switch direction.

Emergency Halt Button

Stops everything on layout; also stops recording playback.

AUX-2/Out Button

Controls switch direction. Toggles all lights on/off, except lights that are wired to track power.

Record Button

Used to record and play back events.

Velocity Throttle

Throttle control over engines, also used to navigate thru info/options.

Set Button

Used to set Engine address and for programming.

Info Button

Used to enter/view the info/options of selected components.

CTC Button

Press and hold to turn your remote on and off. Tap this button to enter the remote and base options. Tap it again to return to the main screen.

Soft Keys

These keys directly correlate to the 5 selection boxes located at the bottom of the main display. These are also used in the info/options menus to select options.

Warning Sound Controller

Warning Bell and Variable Horn control. Pull down to sound Horn. Push up and release to trigger Warning Bell.

Multi Controller

Boost, Brake, and Direction control. Rock forward for Boost, rock backward for engine brake, and press down for direction change. Click-hold-and rock for absolute direction selection.

Front & Rear Coupler Buttons

Fire couplers.

Feedback Button

Toggle ON/OFF the vibration feedback feature in the CAB-2 Remote.

Official R.R. Speed Control Bar

Toggles the touchscreen display of R.R. preset speeds and control panel.

Low, Medium, High Momentum Buttons

Used to select the desired momentum of your addressed engine/train/accessory.

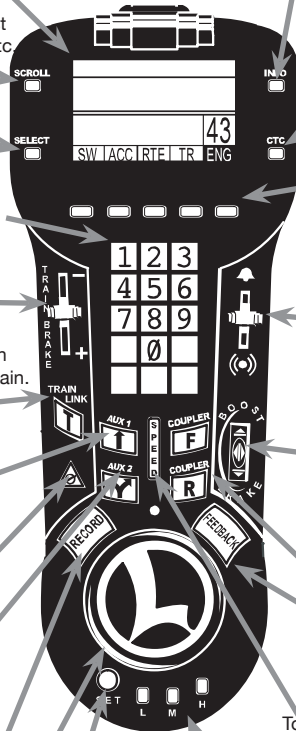

LEGACY Control System operations

Note! This section is a brief overview of the LEGACY Control System. For a more in-depth explanation of the LEGACY Control System features, please see your LEGACY Control System Operations Manual, available online at www.lionel.com.

The Velocity Throttle

The Velocity Throttle (the red rotary knob on the bottom of your Lionel remote) is used to start your engine moving, slow it down, or speed it up. Use it simply by turning it clockwise (speed up) or counter-clockwise (slow down).



The Multi-Controller

Direction

The direction of your engine toggles between forward and reverse at the touch of the Multi-Controller. Press the center of the Multi-Controller once, and your engine's lights will change directions and the engine will stop until you throttle up again in the new direction.

Boost & Brake

Boost and brake give you another way to control the speed of your train. Boost gives your loco a temporary increase in tractive power, and returns to the previous speed when you release the control, while the brake command slows you down more quickly than the Velocity Throttle alone.



The Train Brake Slider

The Train Brake is used to slow down and limit the top speed of your train by adding a load. The more the Train Brake is applied by pulling the Train Brake Slider down, the more laboring is heard from the engine. Eventually Train Brake application will slow down the train and it is even possible to stop a train by pulling the Train Brake Slider all the way down. If your smoke unit is turned on, you'll also see more smoke as the slider is pulled down.

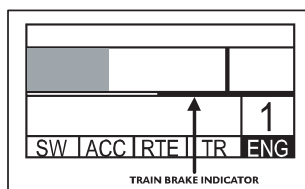
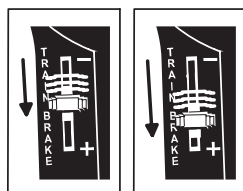

LEGACY Control System operations

The Warning Sound Controller

Warning sounds are an important part of Lionel Railroading. Your Lionel Legacy Control System equipped engines have a real-time variable "quilling" horn.

Blow the Horn by pulling down on the Warning Sound Controller. Notice the difference in intensity of the horn sound.

Strike the bell once by pushing the Warning Sound Controller up and releasing quickly. To activate continuous bell sounds, push the Warning Sound Controller up and hold it for 1.5 seconds. To discontinue the bell sounds, push and hold the Warning Sound Controller up until the bell stops.

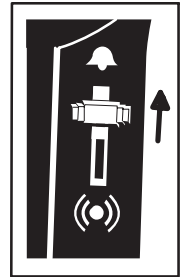

The Speed Bar

The Speed Bar is used to select a new touch-screen Icon Control set. This set of touch-screen keys is used to select prototypical preset speeds. The speed of the engine changes with each press and release of a different Preset Speed key.

- Tap a key, and your locomotive will immediately begin moving to that speed.

You can also use the Velocity Throttle and other action controls in this mode and continue to use Preset speeds at the same time.

Press **AUX1** to leave the Preset speed mode and return to the Standard Control Panel. Press the speed bar to toggle between the Speed Control Panel and the Standard Control Panel.

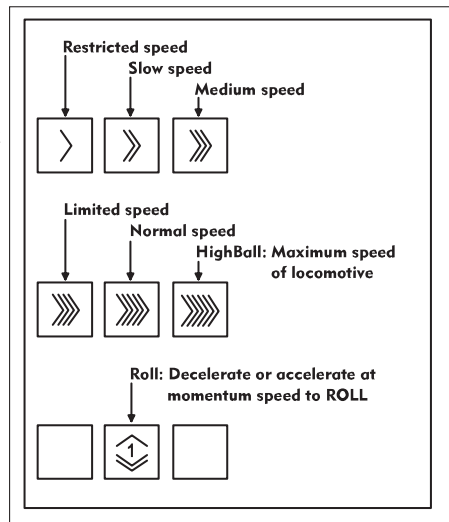

Note! Switcher engines do not have preset speed dialog.

LEGACY Control System operations

EFX Trim and EFX Bar Graph

Sound and smoke effects of the engine can be trimmed higher or lower depending on your operating preference. Pressing the EFX up button will make the engine sound like it is working harder and will also increase the smoke output (if the smoke unit is turned on). Similarly, the EFX down button will decrease the laboring sound of the engine and smoke. A RESET command will return the EFX trim to its default setting.

Notice that the current EFX level is displayed on the remote as a bar graph inside the soft key to the left of the ROLL button. The height of this graph varies with the EFX keys, throttle and train brake adjustments.

Leaving the Preset Speed Screen

Use the Speed Bar to leave the Speed Panel and return to the Control panel. Press the Speed Bar to toggle between the Speed Control Panel and the Standard Control Panel.

LEGACY RailSounds sound system operations

LEGACY RailSounds sound system

Volume UP

Raises the overall master volume of the LEGACY RailSounds sound system. To independently adjust the level of the background sounds only (e.g., the diesel roar and brake sounds), tap AUX1 and then this key.

CrewTalk

Engineer begins radio dialog, dispatcher replies.

RPM Levels

Adjusts the level of the RPM sounds.

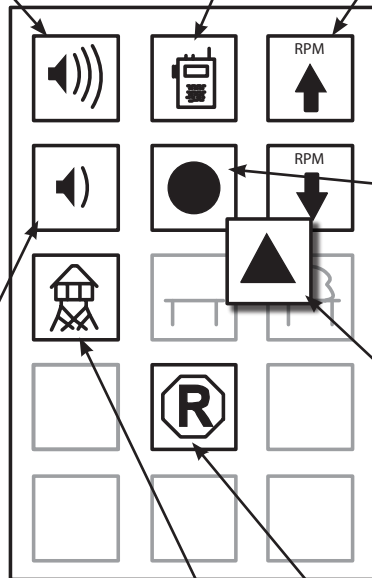

RailSounds Shutdown

Activates the LEGACY RailSounds sound system shutdown sequence when stopped.

Emergency Stop

Activates the emergency stop feature while in motion. (Icon will change as the state of the locomotive changes).

Volume DOWN

Lowers the overall master volume of the LEGACY RailSounds sound system. To independently adjust the level of the background sounds only (e.g., diesel roar and brakes), tap AUX1 and then this key. Volume settings are retaining when track power is turned off.

Stops and resets the locomotive

Resets the locomotive's direction to forward. Press and hold to activate a fueling sequence. Fueling sounds.

TowerCom

Dispatcher begins radio dialog, engineer replies. See page 20.

When adjusting the overall volume, you'll hear a single bell hit that gets louder or softer with each volume adjustment. When the volume is at maximum, additional button presses have no effect and won't play the bell. When adjusting the background sounds (**AUX1**, then a volume key) you'll hear the prime mover volume change without a single bell hit.

LEGACY RailSounds sound system operations

LEGACY RailSounds Sequence Control

Your LEGACY-equipped locomotive features Sequence Control. Based on the movement and speed of the locomotive, Sequence Control automatically plays the sound effects of an entire trip, from departure to destination, while you run your locomotive. Prototypical horn signals, bell, and radio chatter are added automatically as you spin your throttle—no need to memorize a sequence of button presses.

To activate the Sequence Control feature, press and hold the **AUX1** button for three seconds. You'll hear a unique bell/horn signal, indicating that Sequence Control is now enabled. Release the **AUX1** key when you hear the sound.

Now, radio chatter, air brake release, and warning signals will play automatically as you move out, reach cruising speed, and then decelerate for arrival, as illustrated in Figure 6. Plus, you can still activate CrewTalk communication and TowerCom announcements using your remote.

To discontinue Sequence Control, you must tap **AUX1**, and then tap the **0** key or the **RESET** button. Cycling track power off and back on also turns off Sequence Control mode.

Note!

During sequence control mode operation, speed step 1 is used to trigger departure effects such as air brake release and departure horn. Therefore your engine will not begin moving until speed step 2 and the Roll Mode button will bring your engine to a stop while Sequence Control mode is enabled. For the most realistic operation, medium or high momentum is recommended when using Sequence Control.

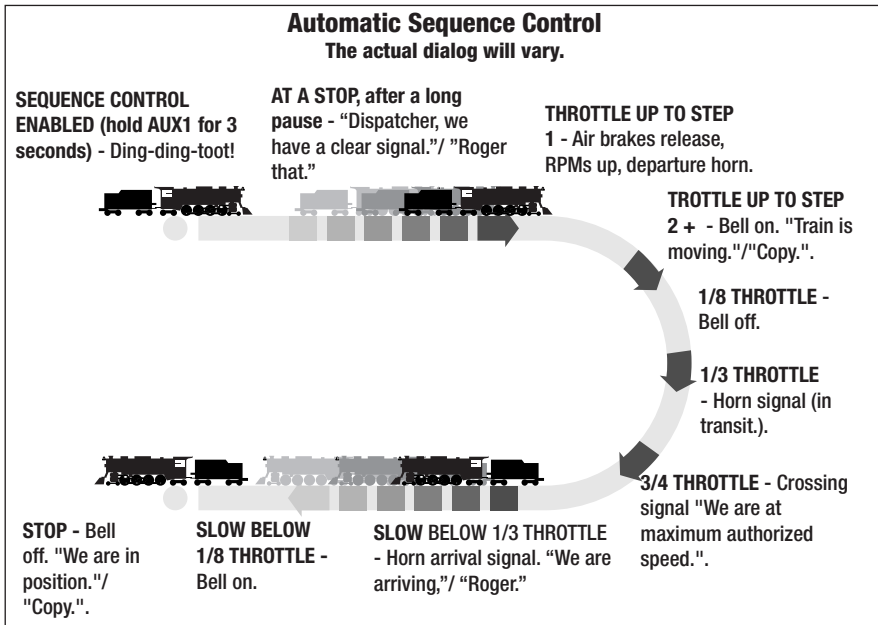

Figure 6. LEGACY RailSounds automatic Sequence Control

LEGACY Control System operations

CrewTalk dialog and TowerCom announcements in the LEGACY environment

In addition to the automatic triggering of dialog via Sequence Control mode operation (see the previous section), you may control the dialog manually.

CrewTalk dialog and TowerCom announcements feature a variety of brief radio conversations between the engineer and dispatcher. CrewTalk dialog is an engineer-initiated radio conversation with the dispatcher. TowerCom announcements are a dispatcher-initiated radio conversation with the engineer. Be sure to listen for the different combinations of words and phrases that comprise these exchanges.

Refer to Table 1 below for the dialog commands. The dialog in the table provides examples of the conversations you can trigger. The actual dialog will vary.

Locomotive	Commands	Example dialog
Stopped	AUX1, 2	Crew: Ask To Depart Tower: Deny Departure
	AUX1, 7	Tower: Ask To Standby Crew: Acknowledge
	2	Crew: Ask To Depart Tower: Approve Departure
	7	Tower: Approve Departure Crew: Acknowledge
	5 or AUX1, 5	Crew: Shutdown Announcement Shutdown sequence
	AUX1, 0 (hold for several seconds)	Refueling sequence Crew: My tank is full
Moving	2	(recent departure) Crew: Train is underway Tower: Acknowledge
	2	Crew: Are we clear ahead? Tower: Acknowledge
	AUX1, 2	Crew: Report engine status, including fuel level
	7 or AUX1, 7*	Tower: Clear in-bound Crew: Acknowledge
	5 or AUX1, 5	Tower: Emergency stop Crew: Acknowledge

*Activating **7** or **AUX1, 7** while the locomotive is in motion enables an arrival conversation for 30 seconds. If the train stops within this time, pressing **2** will play this special conversation.

Table 1. LEGACY Remote Controller dialog commands

LEGACY RailSounds Sound System operations

LEGACY RailSounds sound system dialog on a round trip

Refer to Figure 7 for a sample dialog script for manually controlled dialog on the locomotive's round trip using the numeric keypad. See page 17 for the automatic Sequence Control.

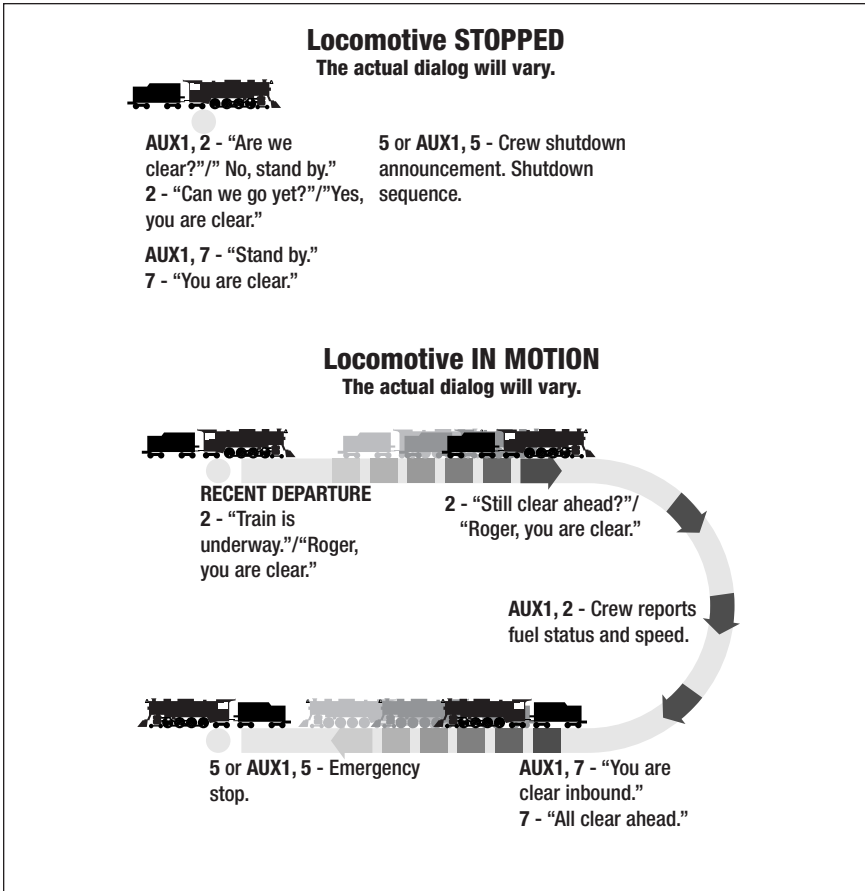

Figure 7. LEGACY RailSounds sound system dialog on a round trip

TrainMaster Command Control operations

CAB-1 Remote Controller commands

The CAB-1 Remote Controller commands are detailed below. The corresponding RailSounds sound system effects are in bold italic type.



Releases the ElectroCoupler on the front of the locomotive. *Coupler release sound.*



Releases the ElectroCoupler on the rear of the tender. *Coupler release sound.*



Activates the numeric keypad. *Short air release sound.*



Controls switch direction. Toggles all lights on/off, except lights that are wired to track power.



Accelerates the locomotive with a clockwise rotation. Decelerates the locomotive with a counter-clockwise rotation. *Speed-dependent RPM sounds.*



Activates the locomotive's horn. Release the button to discontinue the sound. *Horn sound.*



Toggles the bell sound on and off. *Bell sound.*



Changes the locomotive's direction. The locomotive decelerates to a stop and continues in the opposite direction when you increase the throttle. *Air release sound.*



Increases the locomotive's speed while the button is pressed. Release the button to return to the initial speed. *Labored prime mover.*



Decreases the locomotive's speed while the button is pressed. *Squealing brake sounds.*



Shuts down all PowerMasters on your railroad. Stops all TrainMaster Command Control-equipped locomotives in operation. Use HALT only in emergency situations.



Odyssey II Momentum

- L** 32 speed steps with low momentum
- M** 100 speed steps with low momentum
- H** 100 speed steps with medium momentum

TrainMaster Command Control operations

CAB-1 Remote Controller numeric keypad commands

When you press the AUX1 button on your CAB-1 Remote Controller, you turn the numeric keypad into ten command buttons. After you press the **AUX1** button, you will be able to press any numbered button until you address a different product. *The corresponding RailSounds sound system effects are in italic type.*



Stops and resets the locomotive. Resets the locomotive's direction to forward. Your locomotive keeps track of its fuel level. Higher engine speeds and/or heavy labor will use fuel at a faster rate. Press **AUX1, 2** to initiate engine status dialog, including the fuel level. To add fuel, perform a "long reset." When the fuel level is low (or at any time), you may choose to press and hold **AUX1, 0** for at least three seconds. You will hear the sounds of fuel flowing into the tank as long as you hold the button. When you release the button, the sounds will stop and the engineer will confirm that the tank is full. *Refueling sequence.*



Raises the overall master volume of the LEGACY RailSounds sound system. To independently adjust the level of the background sounds only (e.g., the diesel roar and brake sounds), tap **AUX1** and then this key. *Sound volume increases.* When adjusting the overall volume, you'll hear a single bell hit that gets louder or softer with each volume adjustment. When the volume is at maximum, additional button presses have no effect and won't play the bell. When adjusting the background sounds (**AUX1**, then a volume key) you'll hear the prime mover volume change without a single bell hit.



Engineer begins radio dialog, dispatcher replies (see page 18). *CrewTalk communication.*



Enters manual RPM mode and increases the RailSounds sound system RPM level. If the LEGACY RailSounds sound system is shut down (see **5** key below), **AUX1, 3** activates a full LEGACY RailSounds sound system start-up while the locomotive is stopped after pressing **AUX1, 5** with track power on.

TrainMaster Command Control operations

CAB-1 Remote Controller numeric keypad commands (continued)



Lowers the overall master volume of the LEGACY RailSounds sound system. To independently adjust the level of the background sounds only (e.g., diesel roar and brakes), tap **AUX1** and then this key. Volume settings are retaining when track power is turned off. *Sound volume decreases.*



Activates the LEGACY RailSounds sound system shutdown sequence when stopped. Activates the emergency stop feature while in motion. Note that, in the shutdown sequence, the smoke unit will turn off if it was already on.



Enters manual RPM mode and lowers the LEGACY RailSounds diesel motor RPM level.



Dispatcher begins radio dialog, engineer replies (see page 18). *TowerCom announcement.*



Turns off the smoke units. *Air release sound.*



Turns on the smoke unit if the smoke unit switch is in the ON position. Be sure to add smoke fluid before turning on the smoke unit to prevent damage to your locomotive. *Air release sound.*

Note! **AUX1**, **8** and **9** function only if the locomotive's smoke unit switch is in the ON position.

Setting the smoke level

You may adjust the level of smoke production using your Remote. Use the sequences below.

- Low** smoke production: **AUX2, 9, L, AUX2**
- Medium** smoke production: **AUX2, 9, M, AUX2**
- High** smoke production: **AUX2, 9, H, AUX2**

Conventional transformer operations

Using the LEGACY RailSounds sound system in the conventional environment

When you first power up your locomotive, you will hear the sounds of the locomotive at rest. As the locomotive moves, the RPM sounds automatically increase with the locomotive's speed. In the conventional environment, the horn and bell sounds are activated by your transformer controls, if so equipped.

To adjust the volume, use the volume control knob. Refer to Figure 4 on page 8 for the location of the volume control knob.

For proper operation of the LEGACY RailSounds sound system during track power interruptions and for the locomotive shutdown sequence, you must install a nine-volt alkaline battery.

In the conventional environment, you will experience several features of the LEGACY RailSounds sound system.

- **Diesel motor RPM levels.** The level of diesel motor RPM level automatically varies with the speed of the locomotive.
- **MultiHorn.** A different horn sound at different speeds.
- **Mechanical bell.** Press BELL on your transformer to begin the effect, then press BELL a second time to discontinue the effect.
- **CrewTalk dialog and TowerCom announcements.** These brief conversations between the train crew and the tower are triggered by short horn blasts.
- **Reverse unit reset sound.** Power down your track, wait three seconds, and listen for the air-release sound, which is the locomotive telling you that its Lionel Command reverse unit has reset to forward (a nine-volt alkaline battery is required).
- **Shutdown sequence.** When you turn off track power, you have two seconds to power up again after you hear the reverse unit reset sound. If you do not restore power, you will hear the realistic shutdown sequence. Because track power is off, a battery is required for this sequence to function.

Conventional transformer operations

Activating the CrewTalk dialog and TowerCom announcements

In the conventional environment, CrewTalk dialog and TowerCom announcements are triggered by short horn blasts and vary with the state of the locomotive.

- If the locomotive has been stopped for less than 15 seconds, a short horn blast triggers a "please standby" dialog.
- If the locomotive has been stopped for longer than 15 seconds, a short horn blast triggers a "cleared outbound" dialog.
- If the locomotive has started moving within the last seven seconds, a short horn blast will trigger a "train is underway" dialog.
- If the locomotive has been moving for more than seven seconds, a short horn blast will trigger a "are we clear?" dialog.

Conventional transformer operations

Locking your locomotive into a single direction

When the Command reverse unit switch is in the RUN position on the powered unit, your locomotive sequences through a repeating pattern of operations: forward, neutral, reverse, neutral, and so on.

To “lock” your locomotive into a single direction (for example, to operate in forward only), you can deactivate the Command reverse unit’s sequencing function.

- 1. Use your transformer’s DIRECTION button or interruptions in track power to get your locomotive moving slowly in the desired direction or into neutral.**
- 2. Slide the Command reverse unit switch on the powered unit to the PGM position. At this point, the locomotive is “locked” into your chosen direction. See Figure 4 on page 8 for the location of this switch.**

To restore the forward-neutral-reverse sequence, just slide the Command reverse unit switch back to the RUN position.

Odyssey II Speed Control system operations

Odyssey II Speed Control operations

The Odyssey II Speed Control system is “cruise control” for your locomotive. Once the speed control is set, your locomotive will maintain a constant speed, no matter what load is placed on the locomotive or what grades you have on your layout. The Odyssey II Speed Control system also allows for extremely slow movement that will amaze any scale enthusiast.

Odyssey II Speed Control LEGACY Control operation

In LEGACY Control System CAB-2 mode, Odyssey II Speed Control system provides 0-199 speed steps. For a more in-depth explanation of the LEGACY Control System features, please see your LEGACY Control System operations manual, available online at www.lionel.com.

Odyssey II Speed Control TrainMaster Command Control operation

When the Odyssey II Speed Control system is activated, changes in the speed of the locomotive will correspond to each signal from the Command Base. For example, when you address the locomotive and slowly turn the throttle knob, the first flash of the red light on the Command Base corresponds to the first speed step, which is the slowest speed of the locomotive. The locomotive will maintain that speed until you increase or decrease the throttle.

In TrainMaster Command Control CAB-1 mode, Odyssey II Speed Control System now provides selectable resolution and momentum. See the table on page 20.

Odyssey II Speed Control conventional transformer operation

The Odyssey II Speed Control system is automatically operational when you operate your locomotive in conventional (non-Command Control) mode, as long as the Odyssey II Speed Control system switch is in the ON position (see Figure 4 on page 8). This means that your locomotive will maintain a constant speed, compensating for grades, loads, and turns. Simply use your transformer's throttle to adjust the speed of your locomotive.

Note! Because of the way that speed control operates in conventional mode, you will notice a slight delay between adjusting your transformer throttle and the change in the speed of your locomotive. If you desire instantaneous response to throttle changes, turn off the Odyssey II Speed Control system using the Odyssey II Speed Control switch (see Figure 4 on page 8).

Maintaining and servicing your locomotive

Reprogramming your locomotive to restore features

If your locomotive is unresponsive to your commands in the Command Control environment, we recommend that you follow this procedure to reset your locomotive. All factory default settings will be restored when you reprogram the locomotive.

- 1. Slide the program run switch to the PGM position.**
- 2. Plug in and connect your LEGACY Base.**
- 3. Place your locomotive on the track, then power up the track.**
- 4. Press ENG and enter the locomotive's ID#.**
- 5. Press SET.**
- 6. Turn off track power and wait ten seconds.**
- 7. Slide the program run switch back to the RUN position.**

At this point, your locomotive has been reset. Restore power to the track and operate the locomotive as usual. Be sure to use the ID# entered in Step 4.

Maintaining and servicing your locomotive

Lubricating your locomotive

Help your Lionel locomotive lead a long and productive life on your railroad by maintaining it properly. To keep your locomotive lubricated, we recommend that you purchase a Lionel Lubrication and Maintenance Kit (6-62927), available from your authorized Lionel dealer.

When you find that the lubrication points illustrated in Figure 8 appear dry, lubricate your locomotive after you have removed any accumulated dirt and dust. There are two basic rules to keep in mind when you are lubricating your locomotive: use only a small amount of lubrication and avoid getting grease or oil on your locomotive's wheels, roller pick-ups, or the track.

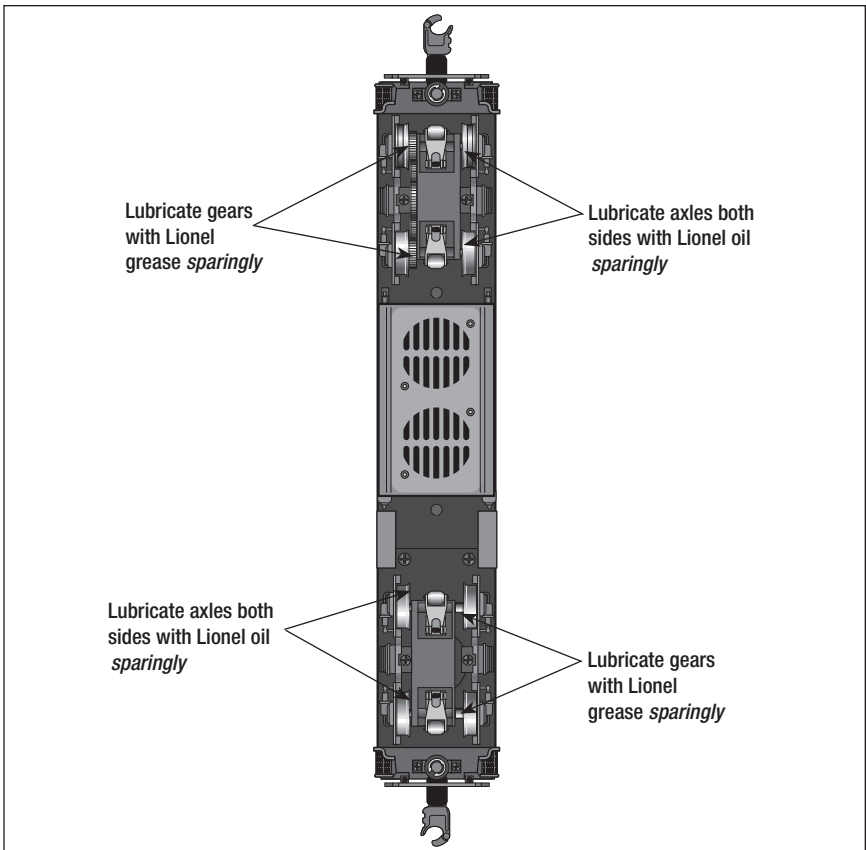

Figure 8. Lubrication points

Maintaining and servicing your locomotive

Servicing your locomotive's LEDs

Note! If the locomotive is powered up and the lights are not on, check that the **AUX2** command was not used to turn the lamps off.

Your locomotive is illuminated by several LEDs that are expected to last for the life of the locomotive. The LED's are not user serviceable. If service is required, we recommend that you have your locomotive serviced at a Lionel Factory Trained Authorized Service Station.

Replacing the traction tires

Your locomotive is equipped with traction tires (Lionel part no. 6208815206) to increase the tractive effort of your locomotive and allow it to pull more cars at once.

During the course of normal operations, the traction tires may become worn out. To replace the traction tires, remove the side frame screws from the underside of the trucks and lift away the side frame. Remove the worn tire, then slip the replacement around the wheel. Reposition the side frame on the truck and secure it with the two screws.

Maintaining and servicing your locomotive

Locomotive diagnostics

Your locomotive includes built-in diagnostics to monitor the condition of the main drive motor and smoke system. If a problem is detected, the locomotive's cab light will blink a diagnostic code.

If you see the light inside the cab flashing, press **RESET** (for LEGACY operation), **0** (for TMCC operation), or **DIRECTION**/power interruption (for conventional operation to attempt to clear the problem. The locomotive will immediately check itself again. If the problem persists, the cab light will blink the code again.

Note that smoke-related errors can be reset a maximum of three times. On the third try, if the problem still persists, the smoke unit will be shut down and must be returned to Lionel Service for repair.

Note!

Turning the smoke unit switch to the off position will disable diagnostic checks of the smoke system.

Number of Blinks	Diagnostic Code Description
1	Main drive motor stalled.
2	Smoke 1 element problem.
3	Smoke 1 fan problem.
4	Not applicable.
5	Not applicable.

Maintaining and servicing your locomotive

Notes

Lionel Limited Warranty Policy & Service

This Lionel product, including all mechanical and electrical components, moving parts, motors and structural components, with the exception of **LIGHT BULBS, LED's & TRACTION TIRES** are warranted to the original owner-purchaser for a period of **one year from the original date of purchase** against original defects in materials or workmanship when purchased through a **Lionel Authorized Retailer***.

This warranty does **NOT** cover the following:

- Normal wear and tear
- Light bulbs or LED's
- Defects appearing in the course of commercial use
- Damage resulting from abuse/misuse of the product

Transfer of this product by the original owner-purchaser to another person voids this warranty in its entirety. Modification of this product in any way; visually mechanically or electronically, voids the warranty in its entirety.

Any warranted product which is defective in original materials or workmanship and is delivered by the **original owner-purchaser** (this warranty is non-transferrable) to Lionel LLC or any Lionel Authorized Service Station **MUST** be accompanied by the original receipt for purchase (or copy) from an **Authorized Lionel Retailer***, will at the discretion of Lionel LLC, be repaired or replaced, without charge for parts or labor. In the event the defective product cannot be repaired, and a suitable replacement is not available, Lionel will offer to replace the product with a comparable model (**determined by Lionel LLC**), if available. In the event a comparable model is not available the customer will be refunded the original purchase price (requires proof of purchase from the **Authorized Lionel Retailer*** it was originally purchased). Any products on which warranty service is sought must be sent freight or postage prepaid (Lionel will refuse any package when postage is due).

Transportation and shipping charges are not covered as part of this warranty.

NOTE: Products that require service that do not have a receipt from an LIONEL AUTHORIZED RETAILER* will be required to pay for all parts required to repair the product (labor will not incur a charge) providing the product is not older than 3 years from date of manufacture and is within 1 year from date of purchase. A copy of the original sales receipt is required.

In no event shall Lionel LLC be held liable for incidental or consequential damages.

Some states do not allow the exclusion or limitation of incidental or consequential damages, so the above exclusion may not apply to you.

This warranty gives you specific legal rights and you may have other rights which vary from state to state.

Instructions for Obtaining Service

If service for this Lionel LLC product is required; bring the item, along with your DATED sales receipt and completed warranty information (at the bottom of this page) to the nearest Lionel Authorized Service Station. Your nearest Lionel Service Station can be found by calling 1-800-4-LIONEL or by accessing the website at www.lionel.com.

If you prefer to send your Lionel product directly to Lionel, for repair you must FIRST call 586-949-4100 extension 9105 or FAX Lionel at 586-949-5429 or write to Customer Service, 26750 Twenty Three Mile Road, Chesterfield, MI 48051-2493. Please have the 6-digit Lionel product number, the date of original purchase, the dealer where the item was purchased and what seems to be the problem. You will receive a return authorization (RA) number to ensure your merchandise will be properly tracked and handled upon receipt at Lionel LLC.

Once you have your Return Authorization (RA) number, make sure the item is packed in its original Styrofoam inner container which is placed inside the original outer display box (this will help prevent damage during shipping and handling). This shipment **MUST** be prepaid and we recommend that it be insured with the carrier of your choice.

Please make sure you have followed all of the above instructions carefully before returning any merchandise for service. You may choose to have your product repaired by one of Lionel LLC's Authorized Service Stations after its warranty has expired. A reasonable service fee should be expected once the product warranty has expired.

Warranty Information

Please complete the information below and keep it, along with your **DATED ORIGINAL SALES RECEIPT**. You **MUST** present this form **AND** your **DATED SALES RECEIPT** when requesting warranty service.

*A complete listing of Lionel Authorized retailers can be found by calling 1-800-4-LIONEL or by visiting our website at www.lionel.com.

Products that are more than 3 years old, from date of manufacture, are not applicable for warranty coverage, even if they have never been sold prior to this date. (Under no circumstance shall any components or labor be provided free of charge.)

Name _____

Address _____

Place of Purchase _____

Date of Purchase _____

Product Number _____

Product Description _____

